



WKV553-A 模组 规格书

版本：V1.1
2023/12/08

声明

本手册中所有模块数据均来源于广东微喇智能科技有限公司实验室测试结果, 仅供使用参考, 并不代表实际结果, 且广东微喇智能科技有限公司不对本手册中的任何数据、内容陈述等信息的操作、使用 (包括但不限于因使用本手册信息而导致的任何侵权风险和责任等) 承担任何保证责任;

广东微喇智能科技有限公司有权根据产品版本及实际情况的变化对手册内容进行任何修改和补充, 且无需另行通知;

本手册中所提及的商标名称、商标、注册商标等知识产权均归各自权利人所有, 未经权利人授权任何人不得擅自冒用;

本手册最终解释权归广东微喇智能科技有限公司所有。

修订历史

版本	修改内容	修订者	日期
V1.0	首次发布	luo	2023/10/18
V1.1	优化了射频数据和参考电路	luo	2023/12/08

目录

声明.....	1
修订历史.....	2
一、 产品概述.....	4
二、 电气参数.....	6
三、 WKV553-A 模组.....	9
四、 回流焊曲线图.....	18
五、 联系我们.....	19

一、产品概述

WKV553-A 模组是由广东微喇智能科技有限公司开发的一款集成 Wi-Fi6+BLE 5.2 双模模组;

该模组搭载了一颗兆易创新的 GD32VW553 芯片, 该芯片内置了一个低功耗的 32 位 RISC-V 处理器, 主频高达 160M, 外设丰富, 支持包括 ADC、SPI、QSPI、I2C、USART、UART 等外设;除了强大的 MCU 功能外,还集成了 2.4 GHz Wi-Fi 6 和 Bluetooth 5.2 (LE), 其中 WIFI6 的相对于传统的 WIFI4 具有高带宽、高并发、低延时和低功耗的特点, 能优化和提升物联网设备性能; 配合 BLE5.2, 能轻松实现蓝牙配网功能, 蓝牙也能独立工作, 作为数据透传等其他功能使用;

WKV553-A 模组适用于广泛的应用领域, 特别是在智能家电、智慧家居、工业互联、消费类和手持设备、电动自行车、物联网设备、通信网关等多种无线应用场景。

该芯片框图如下所示:

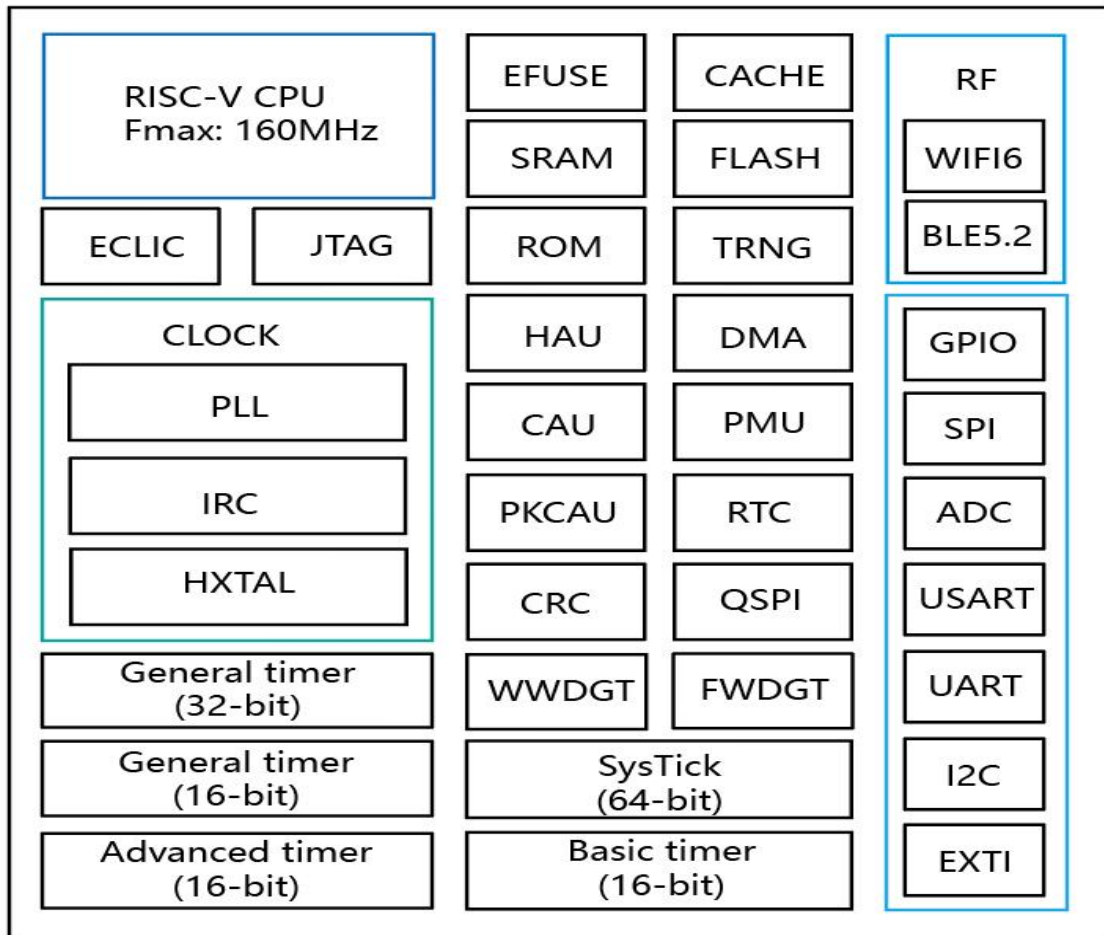

功能特点:

- MCU
 - 低功耗的 32 位 RISC-V 处理器
 - 频率高达 160 MHz
 - 高达 4096KB 的片上 Flash
 - 高达 320KB 的 SRAM

- WIFI
 - 支持 WIFI 2.4GHz IEEE802.11b/g/n/ax
 - 支持 802.11e QoS Enhancement (WMM)
 - 支持 802.11i (WPA, WPA2, WPA3). Open, shared key, and pair-wise key authentication services
 - 支持 WiFi WPS
 - 支持 WiFi Direct
 - 支持 集成 TCP/IP 协议
 - 支持 Target Wake up Time (TWT) operation
 - 支持 Multiple BSSID operation
 - 支持 OFDMA-based random access
 - 支持 Transmission and reception of aggregated MPDUs (A-MPDU) for high throughput
 - 支持 Support for immediate ACK and Block-ACK policies

- BLE
 - 支持 BLE 5.2
 - 支持 High speed 2M PHY
 - 支持 Long range coded PHY
 - 支持 Data rate: 250, 500, 1000 and 2000kbps

- 片上资源
 - 1 个 12 位 ADC
 - 1 个 SPI
 - 1 个 QSPI
 - 2 个 I2C
 - 1 个 USART
 - 2 个 UART
 - Wi-Fi/BLE 无线接口
 - 2 个通用 32 位定时器
 - 2 个通用 16 位定时器
 - 1 个基本定时器
 - 1 个 PWM 高级定时器
 - 加密加速单元 (CAU)
 - 散列加速单元 (HAU)
 - 公钥加密加速单元 (PKCAU)
 - 真随机数生成器 (TRNG)

二、电气参数

(一)、基本参数

1、Absolute Maximum Ratings

Symbol	Parameter	Min.	Max.	Unit
V _{DD}	External voltage range	-0.3	3.6	V
V _{DDA}	External analog supply voltage	-0.3	3.6	V
AVDD33_ANA	RF Analog voltage	-0.3	3.6	°C
AVDD33_PA	RF PA voltage	-0.3	3.6	V
AVDD33_CLK	RF Clock voltage	-0.3	3.6	V
V _{IN}	Input voltage on 5V tolerant pin	-0.3	V _{DD} +3.6	V
	Input voltage on other I/O	-0.3	3.6	V
ΔV _{DDx}	Variations between different VDD power pins	—	50	mV
I _{IO}	Maximum current for GPIO pin	—	±25	mA
T _A	Operating temperature range	-40	+105	°C
T _{STG}	Storage temperature range	-65	+150	°C
T _J	Maximum junction temperature	—	125	°C

(二)、BLE 射频参数

Symbol	Consumption			Unit
Frequency Range	2400~2483.5			MHz
TX power				
Rate mode	Min.	Typ	Max.	Unit
1M	-30	5	15	dBm
2M	-30	5	15	dBm
RX Sensitivity				
Rate mode	Min.	Typ	Max.	Unit
1M	—	-100.5	—	dBm
2M	—	-97.5	—	dBm

(三)、WiFi 射频参数

1、Supported Frequencies

Feature	Description
WLAN Standard	IEEE 802.11 b/g/n/ax WiFi compliant
Frequency Range	2.400 GHz~ 2.4835GHz (2.4 GHz ISM Band)
Number of Channels	2.4GHz :Ch1~Ch14

2、WiFi Power consumption characteristics

Power Mode	Description	Consumption	Unit
Active	Wi-Fi Tx 802.11n, HT 20M MCS0, Pout = +18dBm ⁽¹⁾	316	mA
	Wi-Fi Tx 802.11n, HT 20M MCS7, Pout = +14dBm ⁽¹⁾	275	mA
	Wi-Fi Tx 802.11ax, HE 20M MCS0, Pout = +18dBm ⁽¹⁾	316	mA
	Wi-Fi Tx 802.11ax, HE 20M MCS9, Pout = +12dBm ⁽¹⁾	265	mA
	Wi-Fi Rx 802.11b, CCK 1Mbps, -90dBm ⁽²⁾	99	mA
	Wi-Fi Rx 802.11b, CCK 11Mbps, -80dBm ⁽²⁾	100	mA
	Wi-Fi Rx 802.11g, OFDM 6Mbps, -80dBm ⁽²⁾	101	mA
	Wi-Fi Rx 802.11g, OFDM 54Mbps, -70dBm ⁽²⁾	102	mA
	Wi-Fi Rx 802.11n, HT 20M MCS0, -75dBm ⁽²⁾	100	mA
	Wi-Fi Rx 802.11n, HT 20M MCS7, -65dBm ⁽²⁾	103	mA
	Wi-Fi Rx 802.11ax, HE 20M MCS0, -75dBm ⁽²⁾	101	mA
	Wi-Fi Rx 802.11ax, HE 20M MCS9, -60dBm ⁽²⁾	107	mA
Wi-Fi Sleep	MCU in Run mode ⁽³⁾	37.6	mA
Mild Sleep ⁽⁴⁾	DTIM=1	1.4	mA
	DTIM=3	0.55	mA
	DTIM=10	0.31	mA
Hibernation	MCU in Standby mode ⁽⁵⁾	—	μA
Shutdown	—	—	mA

(1)Continuous Tx, Duty cycle = 100%

(2)Rx Packet Length = 1024 Bytes.

(3)VDD = VDDA = 3.3 V, HXTAL = 40 MHz, System clock = 160 MHz, all peripherals enabled, except Wi-Fi.

(4)The DTIM power consumption is equal to the average power consumption of multiple beacon intervals.

(5)VDD = VDDA = 3.3 V, LXTAL off, IRC32K on, RTC on

3、WiFi RF Performance

3.1 Transmitter Characteristics

Output Power		
Rate	Typical Value(dBm)	EVM(dB)
802.11b/11M	17	≤-23
802.11g/54M	15	≤-33
802.11n/MCS7	14	≤-34.7
802.11ax/MCS9	12	≤-37.2

3.2 Receiver Characteristics

reception sensitivity		
Rate	Channel	Sensitivity(dBm)
802.11b/1M	1	-100.5
	7	-100.5
	13	-100.5
802.11b/11M	1	-91.5
	7	-91.5
	13	-91.5
802.11g/6M	1	-95.5
	7	-95
	13	-95
802.11g/54M	1	-79
	7	-79
	13	-78.5
802.11n/MCS0	1	-95
	7	-95
	13	-94.5
802.11n/MCS7	1	-76.5
	7	-76.5
	13	-76.5
802.11ax/MCS0	1	-95
	7	-94.5
	13	-94.5
802.11ax/MCS9	1	-69
	7	-69
	13	-67.5

三、WKV553-A 模组

(一)、管脚定义

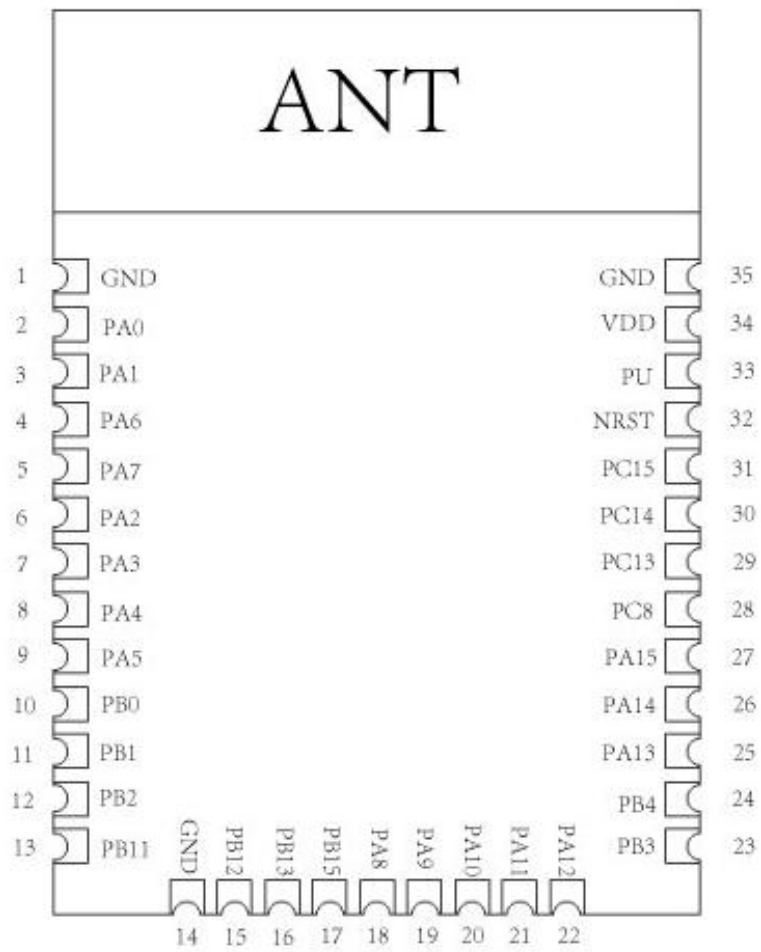

序号	管脚名称	管脚类型	功能说明
1	GND	POWER	Default: GND Ground connections
2	PA0	I/O	Default: PA0 Alternate: USART0_TX, TSI_G0_IO0, USART1_CTS, EVENTOUT, TIMER1_CH0, TIMER1_ETI, TIMER4_CH0 Additional: ADC_IN0
3	PA1	I/O	Default: PA1 Alternate: USART0_RX, TSI_G0_IO1, USART1_RTS, EVENTOUT, TIMER1_CH1, TIMER4_CH1 Additional: ADC_IN1
4	PA6	I/O	Default: PA6 Alternate: I2S1_CKIN, SPI0_SCK, QSPI_IO0, TIMER2_CH0, DCI_PIXCLK, USART2_TX, TIMER0_CH1, TIMER1_CH1, EVENTOUT, SPI0_MISO, I2S1_MCK, SDIO_CMD, HPDF_A UDIO
5	PA7	I/O	Default: PA7 Alternate: SPI1_NSS, I2S1_WS, SPI0_NSS, QSPI_IO1, TIMER2_CH1, DCI_D7, USART2_RX, TIMER0_CH1_ON, TIMER1_CH2, EVENTOUT, TIMER0_CH0_ON, SPI0_MOSI
6	PA2	I/O	Default: PA2 Alternate: USART0_CK, TSI_G0_IO2, TIMER0_CH0, EVENTOUT, TIMER1_CH2, TIMER4_CH2, I2S1_CKIN, USART1_TX, HPDF_AUDIO Additional: ADC_IN2, WKUP0, RTC_TAMP1
7	PA3	I/O	Default: PA3 Alternate: USART1_CK, TSI_G0_IO3, TIMER0_CH0_ON, HPDF_DATA IN1, EVENTOUT, TIMER1_CH3, TIMER4_CH3, I2S1_MCK, USART1_RX, RTC_OUT Additional: ADC_IN3
8	PA4	I/O	Default: PA4 Alternate: I2S1_ADD_SD, SPI1_MOSI, I2S1_SD, SPI0_MOSI, QSPI_SCK, TIMER4_CH2, DCI_HSYNC, USART1_TX, TIMER0_CH1, EVENTOUT, SPI0_NSS, USART1_CK Additional: ADC_IN8
9	PA5	I/O	Default: PA5

序号	管脚名称	管脚类型	功能说明
			Alternate: I2S1_MCK, SPI0_MISO, QSPI_CSN, TIMER4_CH3, DCI_VSYNC, USART1_RX, TIMER0_CH1_ON, EVENTOUT, SPI0_SCK
10	PB0	I/O	Default: PB0 Alternate: TSI_G1_IO0, TIMER3_CH0, TIMER2_CH1, DCI_D4, DCI_D6, EVENTOUT, TIMER0_CH1_ON, SDIO_D1
11	PB1	I/O	Default: PB1 Alternate: TSI_G1_IO1, TIMER3_CH1, TIMER2_CH2, DCI_D3, DCI_D5, EVENTOUT, TIMER0_CH2_ON, SDIO_D2
12	PB2	I/O	Default: PB2 Alternate: TSI_G1_IO2, TIMER3_CH2, TIMER2_CH3, DCI_D2, DCI_D4, EVENTOUT, TIMER1_CH3, SDIO_CK Additional: WKUP2
13	PB11	I/O	Default: PB11 Alternate: USBFS_ID, TSI_G2_IO0, TIMER0_CH1_ON, DCI_D0, DCI_D2, EVENTOUT, I2S1_CKIN, USART2_RX, SDIO_D6
14	GND	POWER	Default: GND Ground connections
15	PB12	I/O	Default: PB12 Alternate: I2S1_WS, USBFS_DP, TSI_G2_IO1, DCI_D1, TIMER0_CH3, EVENTOUT, TIMER0_BRKIN, SPI1_NSS, USART2_CK
16	PB13	I/O	Default: PB13 Alternate: USBFS_DM, TSI_G2_IO2, DCI_D0, EVENTOUT, TIMER15_CH0, TIMER0_CH0_ON, SPI1_SCK, I2S1_CK, USART2_CTS
17	PB15	I/O	Default: PB15 Alternate: I2S1_SD, USART1_TX, USART0_TX, I2C0_SCL, I2C1_SCL, IFRP_OUT, EVENTOUT, RTC_REFIN, TIMER0_CH2_ON, SPI1_MOSI
18	PA8	I/O	Default: PA8 Alternate: CK_OUT0, USART1_RX, USART0_RX, I2C0_SDA, I2C1_SDA, EVENTOUT, TIMER15_CH0, TIMER0_CH0, USART0_CK, USBFS_SOF, SDIO_D1, RTC_OUT
19	PA9	I/O	Default: PA9 Alternate: SPI0_MOSI, SDIO_CMD, SQPI_CLK, QSPI_SCK, EVENTOUT, TIMER15_CH0_ON, TIMER0_CH1, SPI1_SCK, I2S1_CK, USART0_TX, SDIO_D2, DCI_D0

序号	管脚名称	管脚类型	功能说明
20	PA10	I/O	Default: PA10 Alternate: SPI0_MISO, SDIO_D0, SQPI_CSN, QSPI_CSN, EVENTOUT, TIMER16_CH0, TIMER0_CH2, DCI_D1
21	PA11	I/O	Default: PA11 Alternate: SPI0_SCK, SDIO_CK, SQPI_D0, QSPI_IO0, EVENTOUT, TIMER16_BRKIN, TIMER0_CH3, DCI_D2
22	PA12	I/O	Default: PA12 Alternate: SPI0_NSS, SDIO_D1, SQPI_D1, QSPI_IO1, EVENTOUT, TIMER16_CH0_ON, TIMER0_ETI, USART0_RTS, DCI_D3 Additional: WKUP3
23	PB3	I/O	Default: JTDO, TRACESWO, PB3 Alternate: USART2_CTS, SPI0_IO2, SDIO_D2, SQPI_D2, QSPI_IO2, EVENTOUT, TIMER15_BRKIN, TIMER1_CH1, SPI0_SCK, USART0_RX
24	PB4	I/O	Default: NJTRST, PB4 Alternate: USART2_RTS, SPI0_IO3, SDIO_D3, SQPI_D3, QSPI_IO3, TIMER1_CH0, TIMER1_ETI, EVENTOUT, SPI0_MISO
25	PA13	I/O	Default: JTMS, SWDIO, PA13 Alternate: USART0_CTS, USART1_CTS, I2C0_SMBA, EVENTOUT, TSITG
26	PA14	I/O	Default: JTCK, SWCLK, PA14 Alternate: USART0_RTS, USART1_RTS, I2C1_SMBA, EVENTOUT Additional: BOOT1
27	PA15	I/O	Default: JTDI, PA15 Alternate: I2C0_SCL, USART0_RX, I2C1_SCL, EVENTOUT, SPI0_NSS Additional: WKUP1
28	PC8	I/O	Default: PC8 Alternate: I2C0_SDA, USART0_TX, I2C1_SDA, EVENTOUT, TIMER2_CH2, SDIO_D0, DCI_D2 Additional: BOOT0
29	PC13	I/O	Default: PC13 Alternate: USART0_CK, EVENTOUT Additional: RTC_TAMP_0, RTC_OUT, RTC_TS
30	PC14	I/O	Default: PC14 Alternate: USART0_CK, USART1_CK, EVENTOUT Additional: OSC32IN

序号	管脚名称	管脚类型	功能说明
31	PC15	I/O	Default: PC15 Alternate: IFRP_OUT, EVENTOUT Additional: RTC_TAMP0, RTC_OUT, RTC_TS, OSC32OUT
32	NRST	I/O	Default: NRST
33	PU	I	Default: PU
34	VDD	POWER	Default: VDD
35	GND	POWER	Default: GND Ground connections

(二)、尺寸大小

单位:mm

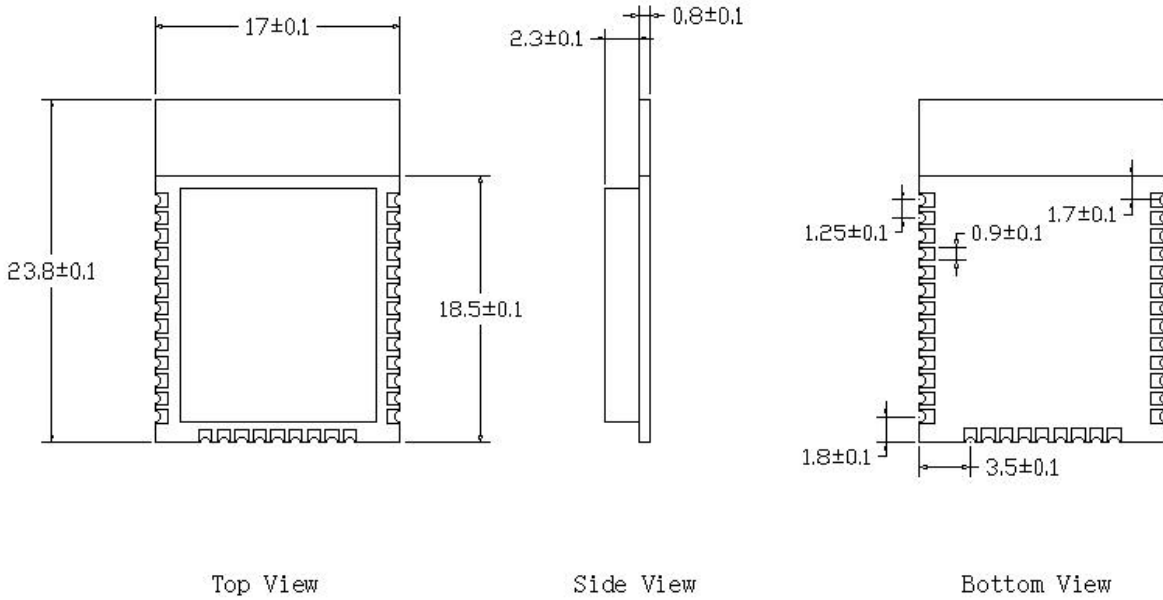

正面

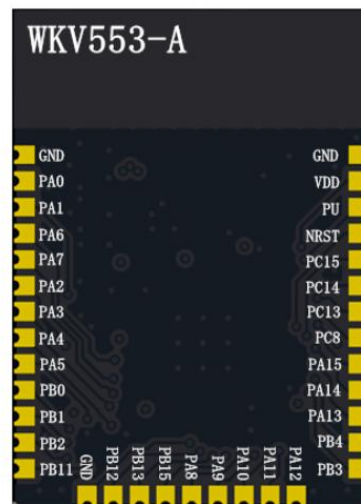

背面

(三)、模组原理图

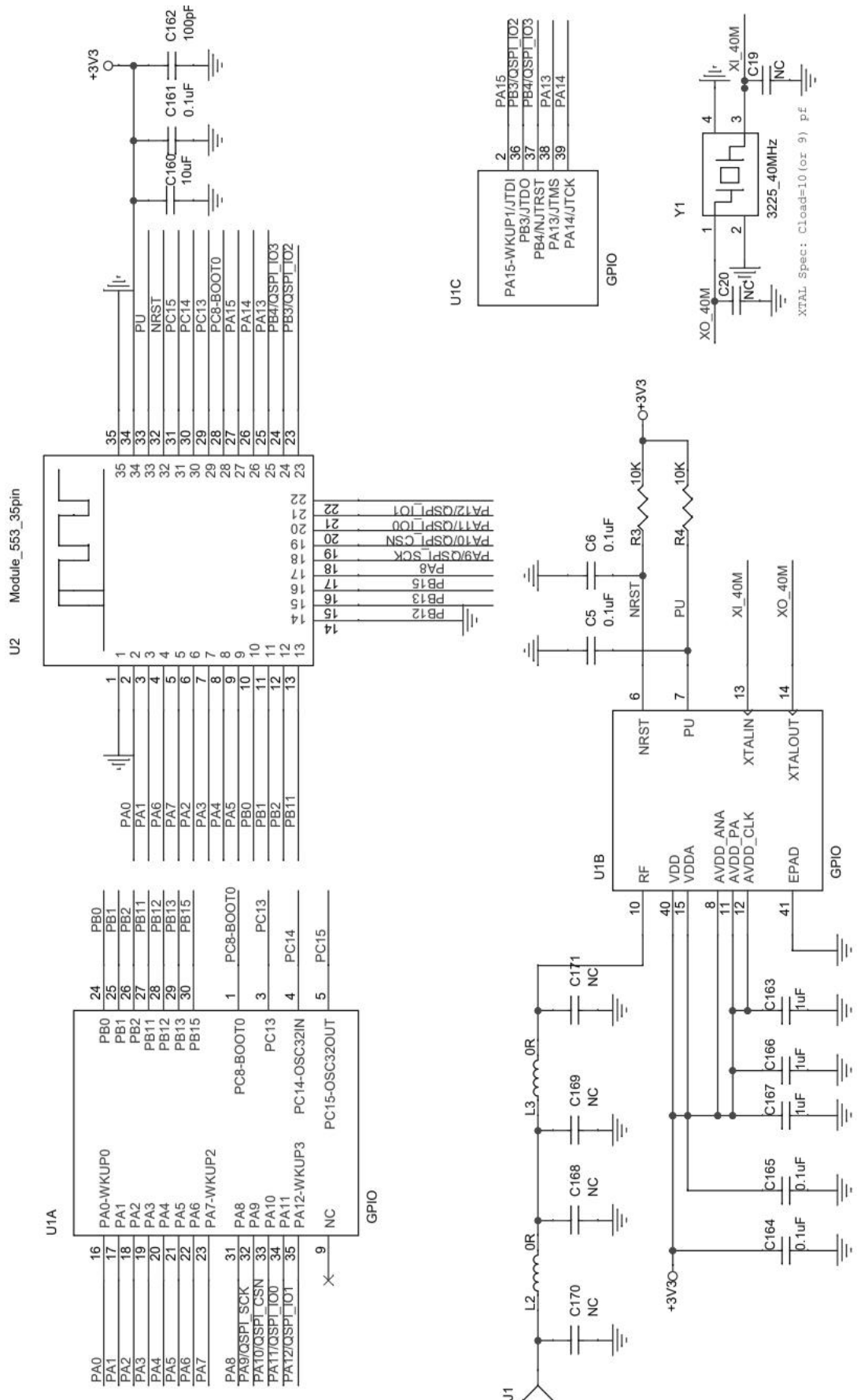

(四)、模组 PCB 封装尺寸

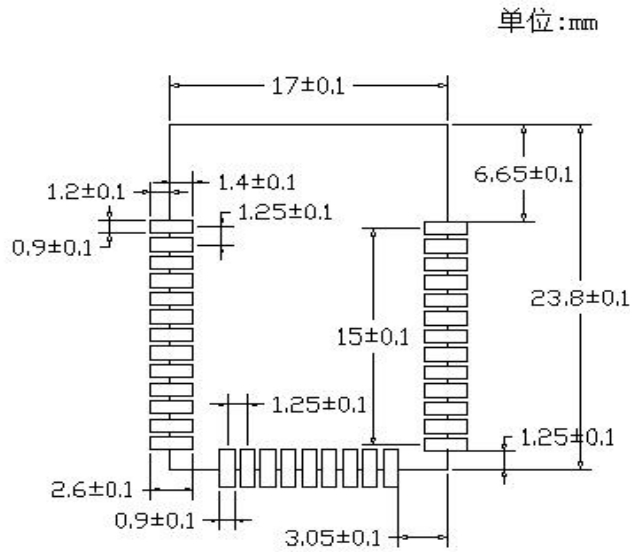

(五)、设计指导

1. 模块应用参考电路

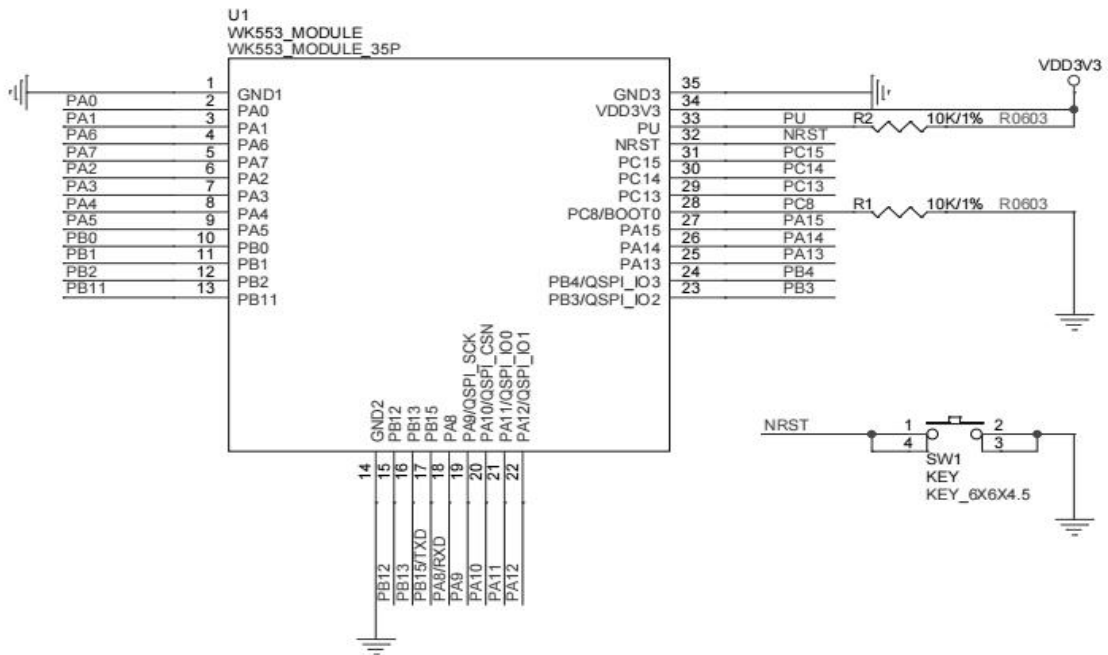

注:

模块 PIN28 脚 PC8/BOOT0 为 BOOT 启动控制引脚，低电平时为模块正常工作，高电平为固件串口下载模式；

为保证模块的正常工作，建议 BOOT0 引脚接一个下拉电阻到地；

2.板载天线摆放要求

为了满足板载天线的性能，禁止在天线周边放置金属件和高频器件，天线摆放推荐下图两种示例摆放：

示例一：

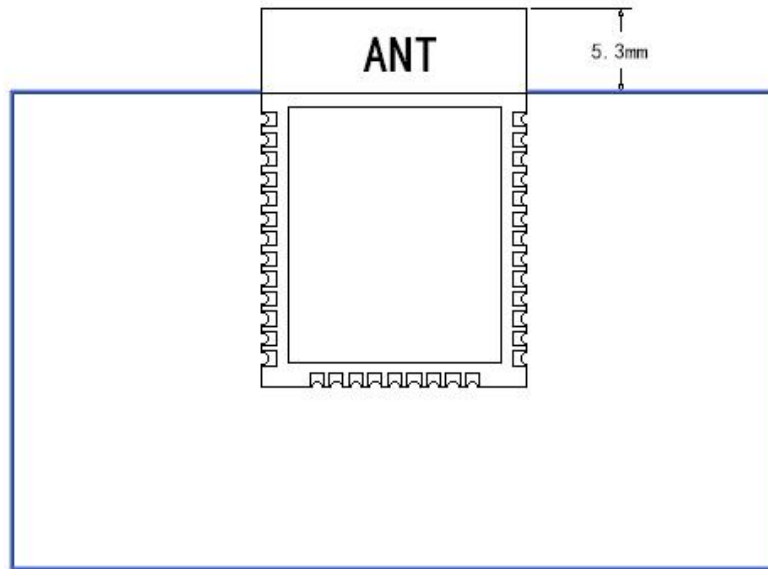

示例二：

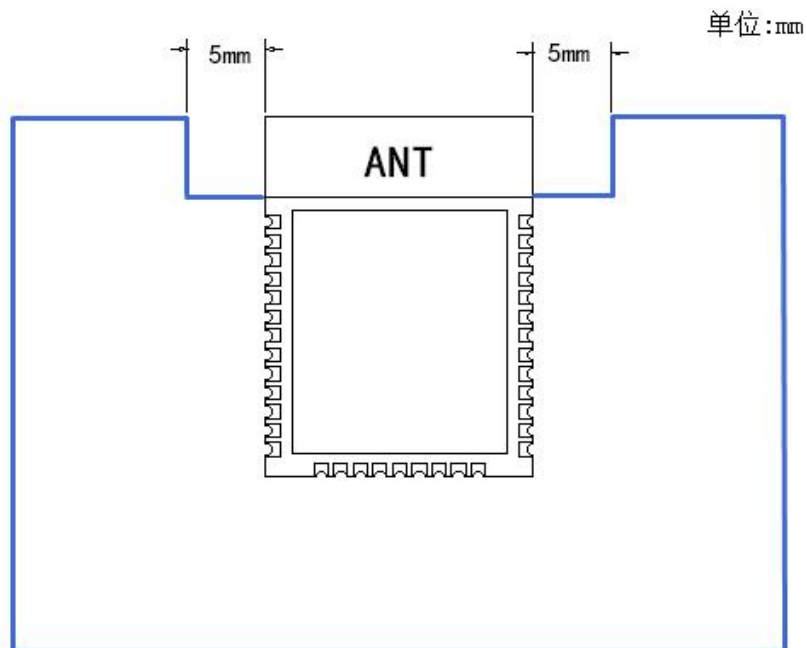

四、回流焊曲线图

1. 参照 IPC/JEDEC 标准。
2. 峰值温度 : < 250°C。
3. 次数 : < 2 次。

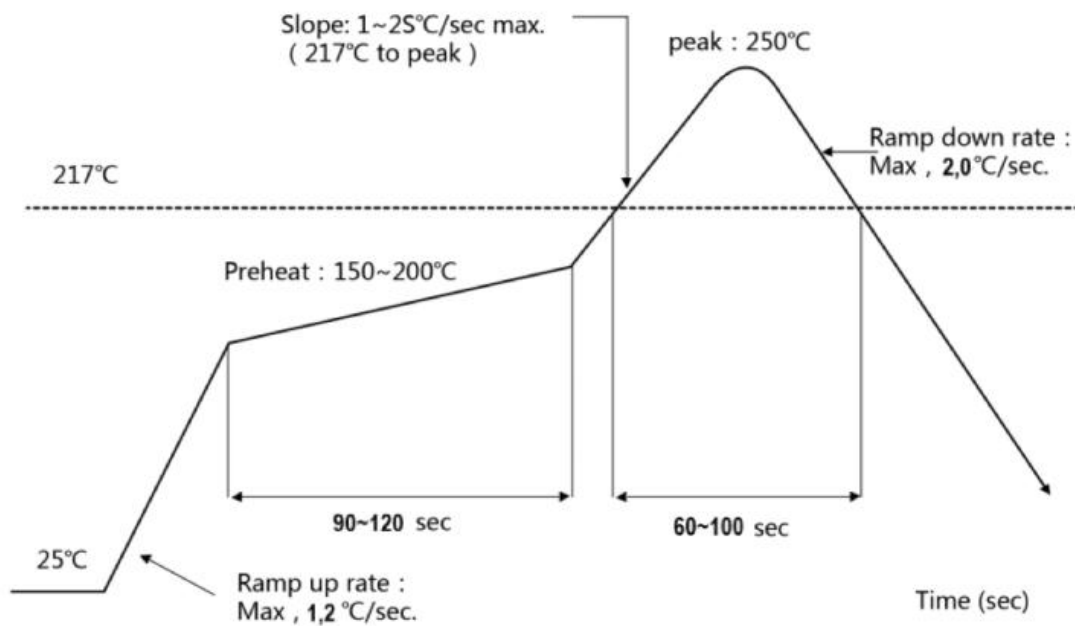

五、联系我们

公 司：广东微喇智能科技有限公司

T E L : 13602688458 (袁先生)

mail : sales@gugutalk.com

电 话：0755-83290418

地 址：深圳市龙华区清祥路 1 号宝能科技园宝创大厦 A 座 11 楼

